

SPHEROMETERS

highly accurate
PC-controlled and
affordable



Super-Spherotronic for high-precision measurements

Super-Spherotronic is an automatic three ball contacting spherometer designed to meet the highest test plate calibration requirements. Being the most accurate instrument of our line of spherometers, Super-Spherotronic can measure the radius of curvature to an accuracy of 0.01%.

To ensure that the highest available accuracy values of radius measurement are obtained, all Super-Spherotronic components have been optimized and perfected so that residual errors are negligible:

- The mainframe components locating the probe are made of massive stainless steel, hardened and fine ground on machine-tools to the highest achievable accuracy. Concentricity of mainframe components to the probe is less than 1 micron (0.00004").
- The spherometer rings represent one of the key components of the Super-Spherotronic including an incredible amount of work to eliminate any possible error source. Made of heat-treated high quality stainless steel, the rings are machined on high accuracy grinding machine tools and finally fine-lapped. An ingenious design combined with a special electro-erosion procedure allows the ball and the ball location site to be matched with highest accuracy. Each ring is delivered with a calibration certificate. The measuring accuracy is directly traceable to NIST standards.
- The supporting balls are also concentrically positioned with an extreme accuracy of less than 1 micron (0.00004"). This highly accurate positioning of the ring balls is an essential and distinctive feature of the Super-Spherotronic, ensuring excellent repeatability. To avoid any thermal and mechanical deformation, the supporting balls are made of





Rings and precision flats of Super-Spherotronic

wolfram carbide (an extremely hard metal), while the probe center is an ultra-precision ruby ball. This completely eliminates any errors introduced by metallic probe centers used in other spherometers.

- The probe itself is a high precision Heidenhain encoder, specifically selected for this use, having a total systematic and random error of less than 0.2 microns (0.000008").
- The test plates used for calibration of the instrument are manufactured to high quality standards to an accuracy better than 1/10 wave for sphericity. The test plates are certified by NIST of USA, so that the accuracy of Super-Spherotronic is directly traceable to international standards.

The fitting of ring diameters to test plates diameters has a significant influence on

the measurement accuracy. As a general rule, to obtain best accuracy, a test plate must be measured with the ring having the largest possible diameter still fitting the test plate.

In this case the largest sagittal height is measured and the smallest relative error results.

The Super-Spherotronic is equipped with a standard set of 6 precision rings with diameters ranging from 7.8 to 120mm. An additional set of precision rings is also available: diameters 14mm, 28mm, 47mm and 75mm.

Normally the standard rings set is sufficient for most of applications. However, when the highest possible accuracy is required or most of the measuring test plates do not fit optimally with the standard rings set, the use of the additional rings set or individual rings belonging to this set are recommended.

Spherocompact for production and quality control

SPHEROCOMPACT is an extremely accurate and easy to use instrument designed for saggita measurement of both concave and convex surfaces.

- SPHEROCOMPACT is the first hand held spherometer with a high precision linear encoder which features bright digital readout, micron resolution and excellent absolute accuracy.



- The calibrated rings have precision grinded reference surfaces and are machined of high quality stainless steel. Ultra-precision RUBY BALLS guarantee highest hardness and unsurpassed thermal stability. The deviation from sphericity is less than 1/10 of a micron.
- The diameter of each ring is certified and the instrument is calibrated using test plates with Certified Radius, traceable to NIST. The calibration is done for both concave and convex spherical sur-

faces. The radius difference between the concave and convex test plates used in calibration is smaller than $\lambda/10$.



SPHEROCOMPACT with rings in wooden box

- Easily removable rings of different diameters increase the versatility of the instrument and feature a very large measuring range covering almost all applications in optical manufacturing.
- The Spherocompact can be used either as a hand-held instrument to take measurements directly on the machine or as a stand-alone instrument in the laboratory.

OPERATION PRINCIPLE

A precision flat is put on the selected spherometer ring. This is the reference (zero) position for the subsequent sample measurement. In the second step the lens or test plate is put on the ring. The spherometer measures the saggital height of the curved surface of the lens.

The radius of curvature can be quickly derived using the relationship between sag and radius:

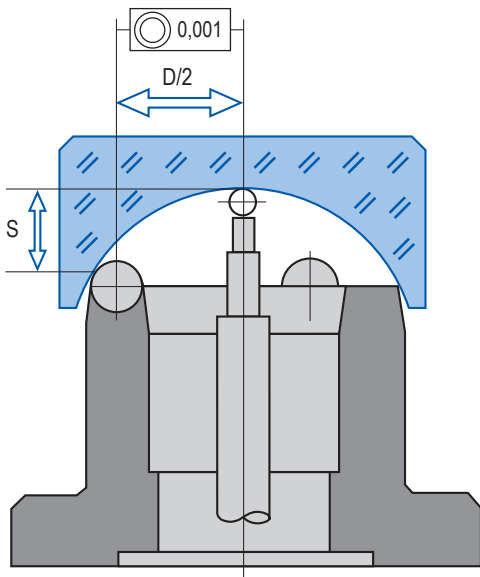

$$R = \frac{(D/2)^2 + S^2}{2S} \pm d/2$$

R = Radius of curvature · D = Diameter of calibrated ring
 S = Sagittal height · d = Diameter of ring ball
 ± = Correction for concave/convex

The values of **D** and **d** are determined with extreme accuracy during the calibration procedure and are certified in the individual calibration sheet supplied with the instrument.

APPLICATIONS

Due to its extreme accuracy and repeatability Super-Spherotronic is primarily used for calibration of master test plates, but also for any measuring problem requiring high precision evaluation of radius of curvature:

- Concave/convex optical parts
- Ground or polished optical parts
- Spheres and balls

Super-Spherotronic can also be used to measure both concave and convex polishing tools, assuring quality standards of

tools and thus reducing subsequent rejected elements.

Spherocompact which is an affordable but accurate instrument, can be used either for in-process measurement of lenses and polishing tools or for the calibration of test plates.

Equipped with special rings, it can measure radius of cylindrical surfaces.

ADVANTAGES

Compared with other radius measuring methods (e.g. interferometers) the spherometric measuring method provides a multitude of advantages:

- the precision spherometers offer for comparable accuracy dramatically reduced costs.
- the measurement time for PC-controlled spherometers is a fraction of the time needed to set up, to align and to take a measurement with interferometers.
- since the measuring procedure is so simple, no highly qualified personnel is required.
- when it comes to measure large aperture optics or radii longer than 1m, the interferometers become impractical due to the high costs or impossibility to realize the extra-long mechanical set up.
- using spherometers the radius can be accurately measured before polishing, when a correction of the lenses is still possible.
- the accuracy of measurement is directly traceable to international standards, since Trioptics spherometers are calibrated with (NIST and NPL) certified test plates.

ADVANCED SOFTWARE

Super-Spherotronic and Spherocompact represent not only the most accurate but also the most useful and efficient spherometers available today. User-oriented software has been developed to really meet the requirements of an easy, quick and errorless measurement.

dividual lenses. This significantly speeds up the measuring procedure and avoids measurement errors.

- The sagittal height, radius of curvature, the current number of the measurement and the type of surfaces (convex/concave) will be automatically displayed and printed out as a certificate of measurement.

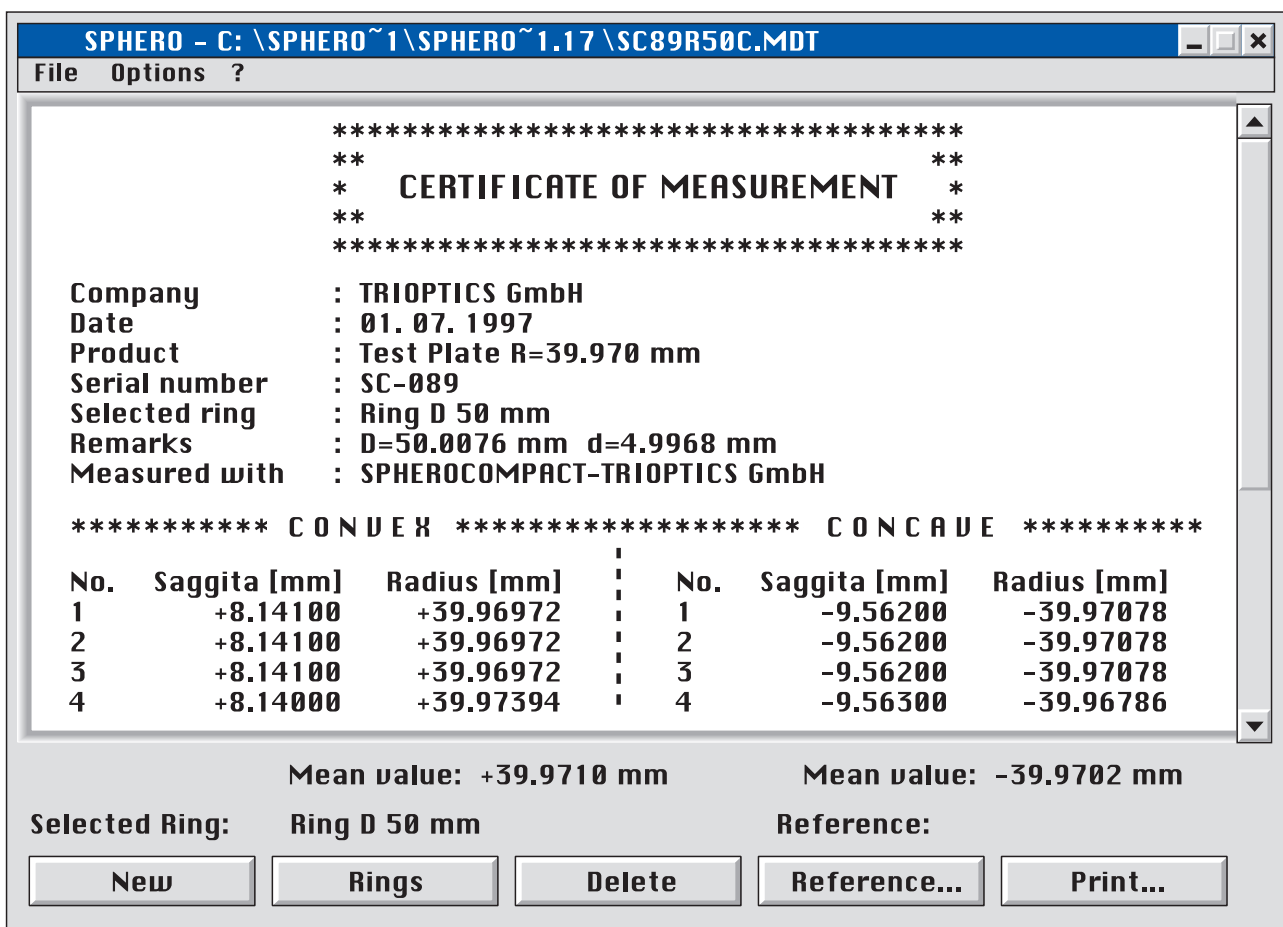

SPHERO - C: \SPHERO~1\SPHERO~1.17\SC89R50C.MDT

File Options ?

```

*****
**                                **
*  CERTIFICATE OF MEASUREMENT  *
**                                **
*****

```

Company : TRIOPTICS GmbH
Date : 01. 07. 1997
Product : Test Plate R=39.970 mm
Serial number : SC-089
Selected ring : Ring D 50 mm
Remarks : D=50.0076 mm d=4.9968 mm
Measured with : SPHEROCOMPACT-TRIOPTICS GmbH

```

***** CONDEX ***** CONCAVE *****

```

No.	Saggita [mm]	Radius [mm]	:	No.	Saggita [mm]	Radius [mm]
1	+8.14100	+39.96972		1	-9.56200	-39.97078
2	+8.14100	+39.96972		2	-9.56200	-39.97078
3	+8.14100	+39.96972		3	-9.56200	-39.97078
4	+8.14000	+39.97394		4	-9.56300	-39.96786

Mean value: +39.9710 mm Mean value: -39.9702 mm

Selected Ring: Ring D 50 mm Reference:

- The SPHEROWIN-Software package runs under Windows `95 in German and English. The measurement results can be displayed in „mm“ or „inch“.
- Only this software package automatically recognizes when measuring convex and concave surfaces and also records automatically the difference when measuring pairs of test plates or individual lenses.
- It provides a statistic evaluation of the measurements including mean value and standard deviation.
- Easy selection of the rings. Calibration data of the rings can be easily stored, displayed or modified.
- On-line help shows the necessary steps to take a measurement.

SUPER-SPHEROTRONIC

MEASUREMENT RANGE

- Radius (Convex): + 3 mm to ∞
- Radius (Concave): - 6 mm to ∞
- Travel of linear encoder: ± 15 mm
- Diameter of part under test: 6 mm to 500 mm

ACCURACY

- Resolution of the linear encoder 0.5 μ m
- Absolute accuracy of the linear encoder ± 0.2 μ m
- Accuracy of measurement of radius of curvature 0.01%

PRECISION BALL RINGS

- Standard set of high precision ball rings in wooden box ranging in sizes (diameters): 7.8 mm, 20 mm, 38 mm, 60 mm, 90 mm, 120 mm,
- Optional: 150 mm, 225 mm
- Position accuracy of balls: ± 0.5 microns for diameters up to 60 mm; ± 1 micron for diameters exceeding 60 mm.
- High precision hard metall balls: Sphericity less than ± 0.1 microns

DIMENSIONS AND WEIGHTS

- Mainframe: Dia. 90 x 260 mm (6.5Kg)
- Digital display: 240x240x70 mm (1.5Kg)
- Wooden box incl. ring set: 380 x 300 x 70 mm

SPHEROCOMPACT

MEASUREMENT RANGE:

- Radius convex: + 2.5 mm to ∞
- Radius concave: -4 mm to ∞
- Diameter of part under test: 5 - 500 mm
- Travel of linear encoder: ± 15 mm

ACCURACY:

- Resolution of the linear encoder: 1 μ m
- Absolute accuracy of the linear encoder: ± 1 μ m
- Accuracy of measurement of radius of curvature 0.05%

PRECISION RUBY BALL RINGS

- Standard diameters: 6mm, 12,5mm, 25mm, 50mm, 75mm, 100mm, 125mm
- Special sizes: 150mm, 225mm

FURTHER FEATURES

- Instantly selectable units mm/inch
- Zero reset at any probe position
- Display: 7-segment LCD
- Height of characters: 8mm
- Interface: RS 232/300 Baud

DIMENSIONS AND WEIGHTS

- Mainframe: 180x70x56 mm
- Mainframe weight: 400 g.

PRECISION FLATS TO BE USED WITH SPHEROCOMPACT OR/AND SUPER-SPHEROTRONIC

- Precision Test Flat Dia. 30 mm $\lambda/10$
- Precision Test Flat Dia. 50 mm $\lambda/10$
- Precision Test Flat Dia. 100 mm $\lambda/5$
- Precision Test Flat Dia. 150 mm $\lambda/3$

TRIOPTICS also designs and manufactures other Optical instruments:

- OPTOMATIC
and OPTOMATIC MICRO

Automated Measurement Stations for testing optical components and systems.

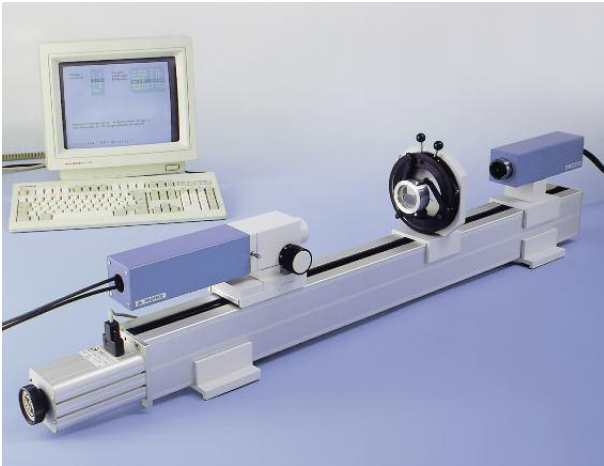

- OptiAngle
PC-controlled Optical Test Station



- OPTITEST a complete range of Optical Test Instruments including auto-collimators, testing telescopes, goniometers, dioptrimeters, camera-test equipment, etc.

Please ask for more information on these products



TRIOPTICS GmbH · Optische Instrumente
Hafenstr. 35-39 · D-22880 Wedel / Germany
Phone: +49 4103 18006 - 0 · Fax: +49 4103 18006 - 20
E-mail: info@trioptics.com
<http://www.trioptics.com>

© 2011 TRIOPTICS GmbH · All rights reserved